

Warewashing Hood Type Dishwasher, Single Skin with Atmospheric Boiler

ITEM # _____

MODEL # _____

NAME # _____

SIS # _____

AIA # _____



505114 (ZHT80)

Hood type dishwasher, with single skin hood, atmospheric 316L boiler, 80r/h - (Middle East)

Short Form Specification

Item No. _____

304 Stainless steel construction to include single skin hood, external, front and side panels, wash tank, tank filter plus wash and rinse arms. Uses 2 liters of clean water per final rinse cycle. 84°C rinse temperature and pressure guaranteed by AISI 304 built in atmospheric boiler and built in rinse booster pump. Washing performance is guaranteed by a powerful 0.8 kW wash pump and upper and lower stainless steel revolving washing spray arms. The unit is equipped with flexible fill hoses. Convertible from straight to corner operation and delivered on height-adjustable feet.

Main Features

- NSF/ANSI 3 and DIN 10512 compliant.
- Maximum capacity per hour of 80 racks or 1.440 dishes (High productivity mode) easy to switch to 63 racks or 1.134 dishes (NSF/ANSI 3 mode) by pressing a button.
- 45/84/150 seconds cycles (High productivity mode); 57/84/150 seconds cycles (NSF/ANSI 3 mode).
- Built-in atmospheric boiler sized to raise incoming cold water to a minimum of 84 °C for sanitizing rinse. No external boiler is required. Constant temperature of 84 °C throughout the rinsing cycle regardless of the network's water pressure.
- Unique temperature interlock guarantees required temperatures in both the wash and final rinse in case of emergency cold water feeding.
- Incorporated Soft Start feature to offer additional protection to more delicate items.
- Slanted wash arms to avoid detergent-filled wash water dropping on clean dishes after the rinsing phase, thus guaranteeing ideal washing results.
- Cycle may be interrupted at any time by lifting the hood.
- Automatic self-cleaning cycle and self-draining vertical wash pump and boiler to avoid bacteria proliferation.
- State-of-the-art electronic controls with built-in programming, self-diagnostics for serviceability and automatic interior self-cleaning cycle.
- IP25 protection against water jets, solid objects and small animals (larger than 6 mm).

Construction

- Heavy duty Stainless steel construction. Internal cavity as well as exterior panels are in 304 series Stainless steel.
- Pressed tank in front position to facilitate cleaning.
- Single skin hood supported by 3 springs to ensure smooth movement and guarantee operator safety.
- Specially designed Stainless steel wash/rinse arms and nozzles provide superior cleaning action.
- Revolving interchangeable Stainless steel wash/rinse arms above and below the rack, screw out for simple clean up.
- Pre-arranged for on-site HACCP implementation and Energy Management device.
- Element protection from dry fire and low water.
- 316L stainless steel boiler with higher welding protection improves resistance to corrosion caused by chlorinated water.

Sustainability

- The machine can be connected to cold water.
- Requires only 2 liters of water per washing cycle thus ensuring low energy, water, detergent and rinse aid consumption.

APPROVAL: _____

Included Accessories

- 1 of Yellow cutlery container PNC 864242
- 1 of Basket for 18 dinner plates or 27 side plates (max. diam. 240 mm) PNC 867002

Optional Accessories

- Kit 8 plastic boxes for cutlery - yellow PNC 780068
- External manual water softener - 12 lt PNC 860412
- External automatic water softener - 8 lt PNC 860413
- External manual water softener - 20 lt PNC 860430
- Connectivity kit for Single Skin Hood Type Dishwashers (ECAP) PNC 864006
- Stainless steel inlet hose kit PNC 864016
- Filter for partial demineralization PNC 864017
- Kit to measure total/partial water hardness PNC 864050
- Yellow cutlery container PNC 864242
- Advanced filtering system kit for single skin hood type PNC 864329
- Drain pump kit for hood type PNC 864346
- Filter for total demineralization PNC 864367
- Rinse aid dispenser kit PNC 864368
- Detergent dispenser kit PNC 864369
- Front control panel for single skin hood type dishwasher PNC 864374
- External reverse osmosis filter for single tank Dishwashers with atmosphere boiler and Ovens PNC 864388
- Delimiting device kit for Hood Type (drain pump included) PNC 864391
- Pressure reducer for single tank dishwasher PNC 864461
- Kit of rack and support to wash fryer basket PNC 864463
- Kit of 100mm feet for Hood Type Dishwasher PNC 864464
- Connecting kit for duet manual hood type dishwasher PNC 865264
- Feet for hood type - marine PNC 865492
- Extra heavy rack support for hood type dishwasher PNC 865493
- Set of 4 yellow cutlery containers PNC 865574
- Basket for 6 trays 530x370 mm PNC 866743
- Basket for 12 soup plates or 12 cups (max. diam. 240 mm) PNC 867000
- Basket for 18 dinner plates or 27 side plates (max. diam. 240 mm) PNC 867002
- Basket for cups and coffee cups (24-48 pcs) - blue PNC 867007
- Basket for bulk cutlery-capacity: 100 pieces - brown PNC 867009
- Cover grid for small/light items in rack PNC 867016
- Basket for 25 glasses max. height: 120 mm diameter: 80 mm - blue PNC 867021
- Basket for 16 glasses max. height: 70 mm - blue PNC 867023
- Basket semi-professional (500x500x190mm) PNC 867024
- Basket for 16 glasses max. height: 220 mm diameter: 100 mm - blue PNC 867040

Front

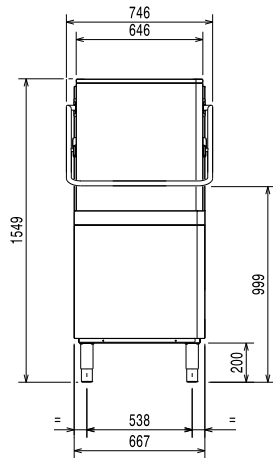

Side

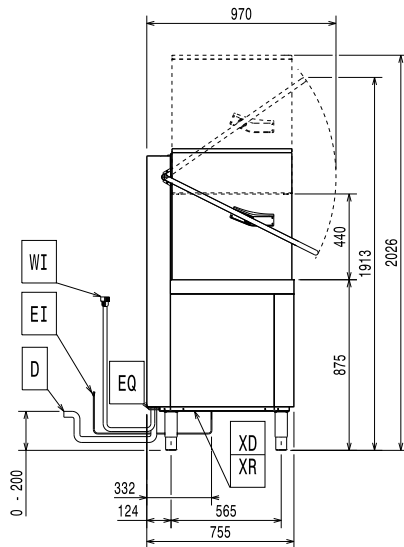

- CW11** = Cold Water inlet 1 (cleaning)
- D** = Drain
- EI** = Electrical inlet (power)
- EO** = Electrical Outlet
- HWI** = Hot water inlet
- WI** = Water inlet

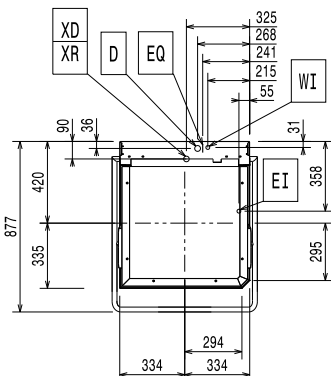

Top

Electric

Supply voltage:	400 V/3N ph/50 Hz
505114 (ZHT80)	
Convertible to:	230V 1N~; 230V 3~
Default Installed Power:	9.9 kW
Boiler Heating Elements Power:	9 kW
Boiler heating elements:	9 kW
Tank heating elements:	3 kW
Wash pump size:	0.8 kW

Water:

Drain line size:	20.5mm
Inlet water supply pressure:	0.5-7 bar
Boiler Capacity (lt):	12
Tank Capacity (lt):	24

Key Information:

N° of cycles:	3
Duration cycle:*	45/84/150 sec.
Duration cycle - NSF/ANSI 3 compliant:	57/84/150 sec.
Racks per hour:*	80
Racks per hour - NSF/ANSI 3 compliant:	63
Dishes per hour:*	1440
Dishes per hour - NSF/ANSI 3 compliant:	1134
Wash temperature:	55-65 °C
Wash temperature - NSF/ANSI 3 compliant:	75 °C
Rinse temperature:	84 °C
Net weight:	106 kg
Shipping weight:	116 kg
Shipping volume:	1.23 m³
Packaging size (WxDxH):	920x770x1730 mm

** When connected to cold water, the cycle time will be prolonged accordingly. The machine will have productivity per hour of 48 racks at 10°C supply temperature or 55 racks at 20°C supply temperature.

Air Emission:

Latent heat:	500 W
Sensible heat:	2000 W

Sustainability

Water supply temperature*:	10-65 °C
Water consumption per cycle (lt):	2
Noise level:	<68 dBA

